



Continuous Dough Feeder

Model: GBCDF

Operating Features

Global's Continuous Dough Feeder is an automated way of feeding your bagel or other rotary knife type dividers. The feeder accepts dough from a horizontal, dump mixer or bowl lift with a hopper capacity up to 550lb of finished dough. Easy to use control panel with PLC control. Sensors to stop the feeder allowing it to keep up with the divider.



Features

- Hopper capacity up to 550lbs
- Sensors to stop feeding
- Easy to maintain
- Stress Free dough Portioning
- PLC Control
- Heavy duty construction
- Teflon coated hopper and knives



BAKERY & FOOD EQUIPMENT CO. LTD.

891 Rowntree Dairy Rd, Woodbridge, Ontario, Canada, L4L 5W3
Tel: (905) 264-0541, Fax: (905) 264-0949 Toll Free (800) 361-0343
Email: info@globalbakery.com Web: www.globalbakery.com

Table 1: Technical Specifications

220/380 Volt, 3 Phase, 60 Hz, 10 Amp
Weight : 800lbs

Table 2: Dimensions

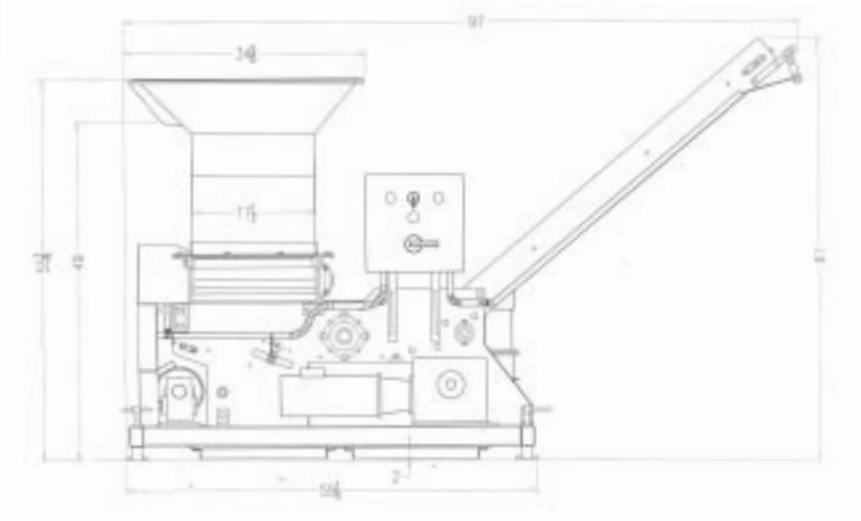

Floor model
Ideal for Horizontal
and Dump mixers

Elevated Model
Ideal for bowl lifts

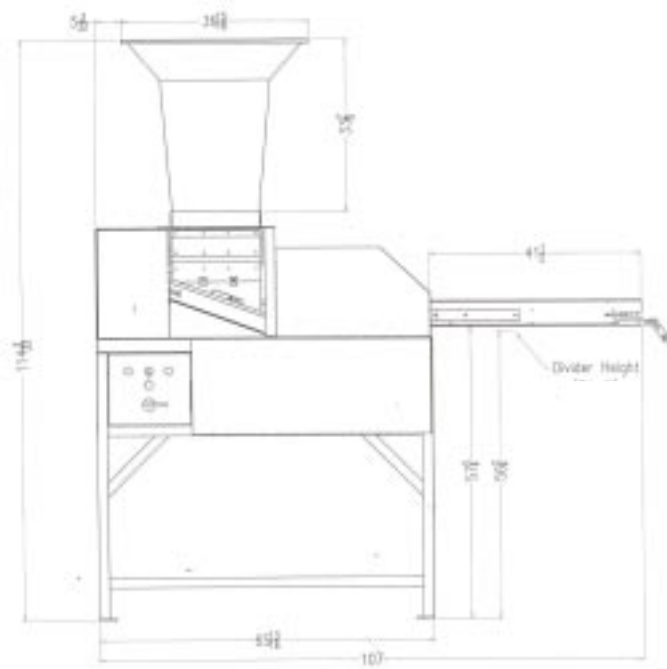

BAKERY & FOOD EQUIPMENT CO. LTD.

891 Rowntree Dairy Rd, Woodbridge, Ontario, Canada, L4L 5W3
Tel: (905) 264-0541, Fax: (905) 264-0949 Toll Free (800) 361-0343
Email: info@globalbakery.com Web: www.globalbakery.com